

SINGLE POLE SOCKETS - SOLDER MOUNT - MOULDED GUIDED ENTRY

Dimensions in inches (mm)

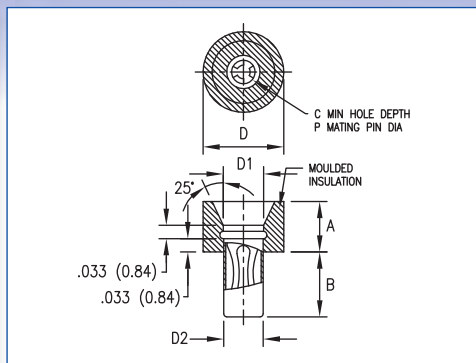

How to order code

450 - 1826 - 01 - 03 - 20

Basic Part No. | Insulator Colour | Socket Finish

Material Code Table		Material
Jack:	Body	Brass
	Spring	Beryllium Copper (Heat Treated)
Insulator		Nylon

Finish Code Table			
Dash No.	Body Finish	Spring Finish	RoHS
-03	Gold over Nickel	Gold over Nickel	✓

Insulation Colour Code Table	
Dash No.	Colour
-20	Natural

Basic Part No.	P	A	B	D	D1	D2	C	Mtg. Hole Diameter
450-1826-01	.061 (1.55)	.125 (3.18)	.162 (4.11)	.200 (5.08)	.093 (2.36)	.098 (2.49)	.250 (6.35)	.102 (2.59)

SINGLE POLE SOCKETS - INSULATED - THREAD MOUNT

Dimensions in inches (mm)

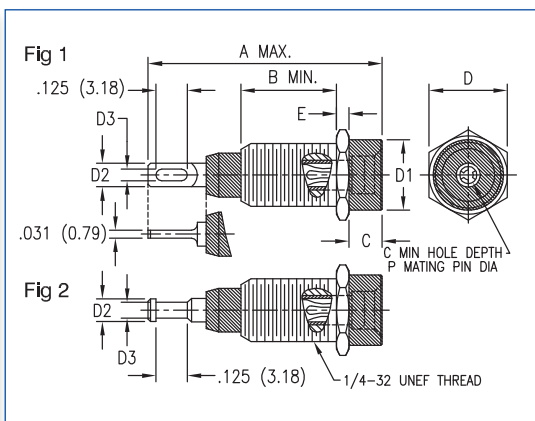

How to order code

450 - XXXX - 01 - 03 - XX

Basic Part No. | Insulator Colour | Terminal Finish

Material Code Table		
Component	Material	RoHS
Insulator (450-3358 & 450-3381)	Nylon	✓
Insulator (450-3359 & 450-3382)	PTFE	✓
Metal Sleeve	Brass	✓
Socket Body	Brass	✓
Socket Spring	Beryllium Copper (Heat Treated)	✓
Mounting Hex Nut	Brass	✓
Internal Tooth Lockwasher	Phosphor Bronze	✓

Finish Code Table							
Dash No.	Socket Body Finish	Socket Spring Finish	Metal Sleeve Finish	Mtg. Hex Nut Finish	Lockwasher Finish	RoHS	
-03	Gold over Nickel	Gold over Nickel	Nickel	Nickel	Nickel	✓	

Insulation Colour Code Table	
Dash No.	Colour
-10	Black
-12	Red*
-16	Blue
-19	White

Fig.	Basic Part No.	A	B	C	D	D1	D2	D3	E	C	P	Dielectric Withstand Voltage (rms)	Insulator
1	450-3358 -01	1.000 (25.4)	.375 (9.53)	.131 (3.33)	.312 (7.92)	.281 (7.14)	.093 (2.36)	.047 (1.19)	.050 (1.27)	.540 (13.72)	.080 (2.03)	3000	Nylon
	450-3359 -01	1.000 (25.4)	.375 (9.53)	.131 (3.33)	.312 (7.92)	.281 (7.14)	.093 (2.36)	.047 (1.19)	.050 (1.27)	.540 (13.72)	.080 (2.03)	3000	PTFE
2	450-3381 -01	1.000 (25.4)	.375 (9.53)	.131 (3.33)	.312 (7.92)	.281 (7.14)	.090 (2.29)	.062 (1.57)	.050 (1.27)	.540 (13.72)	.080 (2.03)	3000	Nylon
	450-3382 -01	1.000 (25.4)	.375 (9.53)	.131 (3.33)	.312 (7.92)	.281 (7.14)	.090 (2.29)	.062 (1.57)	.050 (1.27)	.540 (13.72)	.080 (2.03)	3000	PTFE

Mounting Hardware supplied un-assembled. *Red PTFE is NOT RoHS compliant